

Inhalt Schrank

Contents cabinet / Sommaire armoire

Konstruktions-Information / Design data / Informations sur la construction

		Seite / Page / Page
Karteischränk	Lochreihe 25 mm, EB=762 mm	40
	Lochreihe 32 mm, EB=762 mm	41

Breitschublade / Wide metal drawer / Tiroir large

Breitschublade	ZMS 941, 943	EB=562/762 mm	42
Belegschublade	MB 941, 943	EB=562/762 mm	43

Schubladenführungen / Drawer slides / Coulisses des tiroirs

Differentialauszug	MR 713	EB=562/762 mm	44
Differentialauszug	MR 713	EB=580/780 mm	45

Zubehör zu Breitschublade / Accessories / Accessoires

Parallelführung	MR 810	EB=562-762 mm	46
Einzugsdämpfer	ECD		47

Organisationsmaterial zu Breitschublade / Accessories / Accessoires

Kunststoff			48
Metall			50

Konstruktions-Information / Design data / Informations sur la construction

Registraturschränk	Lochreihe 25 mm, EB=762 mm	52
	Lochreihe 32 mm, EB=762 mm	53

Kombi-Hängerahmen / Combo filing frame / Cadre dossiers suspendus

Kombi-Hängerahmen	KHR 935	EB= 560/ 562 mm	54
Kombi-Hängerahmen	KHR 936	EB= 760/ 762 mm	
Kombi-Hängerahmen	KHR 937	EB= 960/ 962 mm	
Kombi-Hängerahmen	KHR 938	EB=1160/1162 mm	

Schubladenführungen / Drawer slides / Coulisses des tiroirs

Differentialauszug	MR 931	EB=560-1162 mm	56
Differentialauszug	MR 931	EB=580-1180 mm	57

Zubehör zu Kombi-Hängerahmen / Accessories / Accessoires

Parallelführung	MR 809	EB=562-1162 mm	58
Einzugsdämpfer	ECD		59
Metall			60

Organisationsmaterial zu KHR / Accessories / Accessoires

Kunststoff			62
Metall			63

Klappbeschlag / Flipper door / Coulisse pliante pour couvercles ou clapets

Klappbeschlag	MR 136	EB=760-1162 mm	64
---------------	--------	----------------	----



Design data / Informations sur la construction

Pattern of holes / Perf. tous les 25 mm

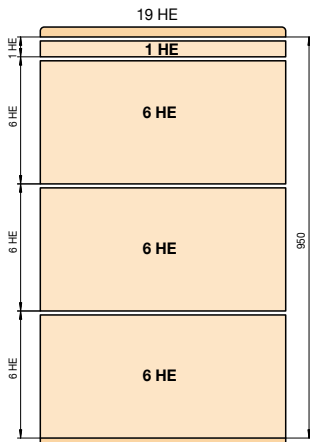

- Die Zeichnungen zeigen Beispiele für die Konstruktion eines Registratorschranks. Basis sind Lochreihen im Abstand von 25 mm (vertikal 25 mm, horizontal 32 mm). Der Registratorschrank ist in der Höhe variabel und somit auch die Anzahl der HE. Die Blende ist ein Mehrfaches der Höheneinheit (HE) -3 mm Luft.
- Illustration of a filing cabinet. Based on a pattern of holes every 25 mm vertically and 32 mm horizontally. The filing cabinet is variable in the total height, therefore also the number of the units of height HE. The front panel is a multiple of the unit of height (HE) minus 3 mm for space.
- Les dessins montrent des exemples de constructions d'armoires pour archives. Ils ont pour base des rangées de perforations espacées de 25 mm (verticalement 25 mm et horizontalement 32 mm). L'armoire pour archives est variable en hauteur et donc également en nombre d'unités dans le sens vertical HE. Le panneau frontal est un multiple de l'unité de hauteur (HE) moins 3 mm de jeu.

Höheneinheiten HE
Raster 25 mm

1	HE =	50 mm
6	HE =	300 mm
19	HE =	950 mm

Typ	Breite EB mm	Mass A mm	Mass B mm	Mass C mm
Typ Type	Width Largeur	Measure Mesure	Measure Mesure	Measure Mesure
KHR 935.35	562	376		66
KHR 936.35	762	128	224	66
KHR 937.35	962	320	224	70
KHR 938.35	1162	512	224	74

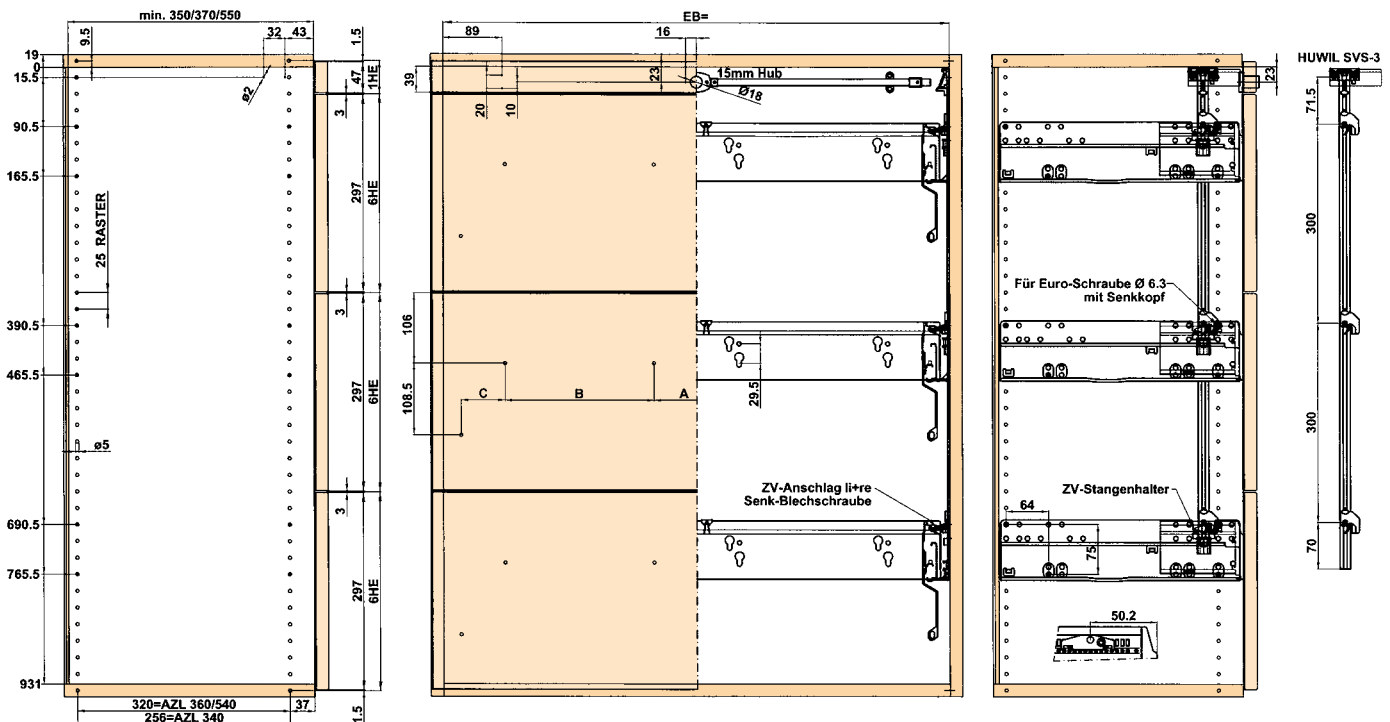

Konstruktions-Information

Lochreihe 32 mm, EB = 562-1162 mm

Design data / Informations sur la construction

Pattern of holes / Perf. tous les 32 mm

- Die Zeichnungen zeigen Beispiele für die Konstruktion eines Registraturschranks. Basis sind Lochreihen im Abstand von 32 mm (vertikal und horizontal). Der Registraturschrank ist in der Höhe variabel und somit auch die Anzahl der HE. Die Blende ist ein Mehrfaches der Höheneinheit (HE) - 3 mm Luft.
- Illustration of a filing cabinet. Based on a pattern of holes every 32 mm vertically and 32 mm horizontally. The filing cabinet is variable in the total height, therefore also the number of the units of height HE. The front panel is a multiple of the unit of height (HE) minus 3 mm for space.
- Les dessins montrent des exemples de constructions d'armoires pour archives. Ils ont pour base des rangées de perforations espacées de 32 mm (verticalement et horizontalement). L'armoire pour archives est variable en hauteur et donc également en nombre d'unités dans le sens vertical HE. Le panneau frontal est un multiple de l'unité de hauteur (HE) moins 3 mm de jeu.

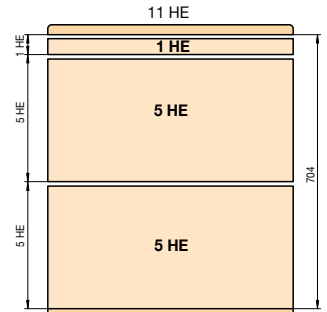

Höheneinheiten HE
Raster 32 mm

1	HE =	64 mm
5	HE =	320 mm
11	HE =	704 mm

Typ Type	Breite EB mm Width Largeur	Mass A mm Measure Mesure	Mass B mm Measure Mesure	Mass C mm Measure Mesure
KHR 935.35	562	376		66
KHR 936.35	762	128	224	66
KHR 937.35	962	320	224	70
KHR 938.35	1162	512	224	74

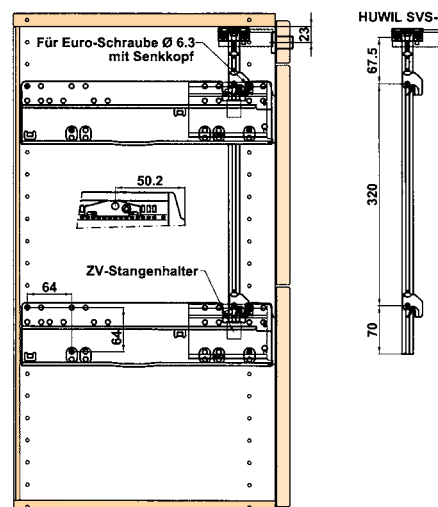
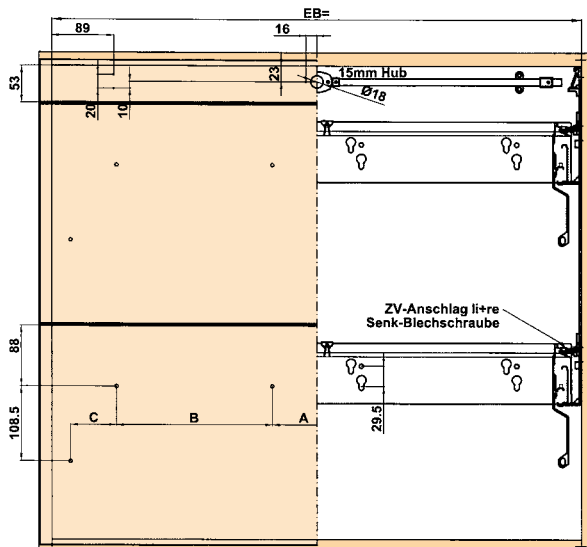
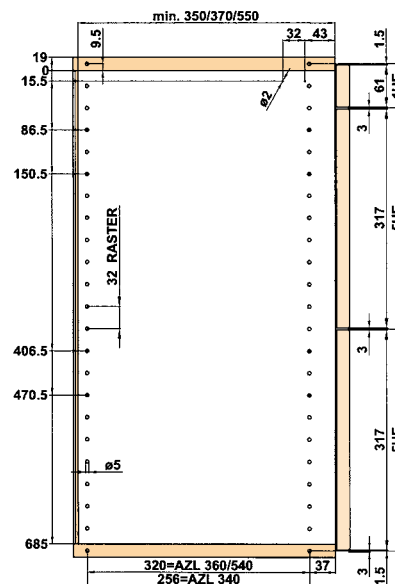

Mass- und Konstruktionsänderungen vorbehalten.
The manufacturer reserves the right to change the specification without notice.
Sous réserve de modifications de construction.

MERZROLLER®

Kombi-Hängerrahmen KHR 935 - 938

Combo filing frame / Cadre dossiers suspendus

- Stabiler, verwendungssteifer Kombi-Hängerrahmen, formschönes, geradliniges Design, beidseitig verwendbar, inkl. Zwischenstege und Abdeckkappen, Schlüsselöcher zur Befestigung der Blende oder Schlitz für Beschriftungsschild, mit Zubehör ist ein Umbau zur Breitschublade möglich
- Stable, torsion-resistant hanging file frame, elegant straight design, 2 alternate sides (1x panel side/1x label side), includes end cover plates and file suspension rails, easily convertible to a wide metal drawer with available accessories
- Cadre pour dossiers suspendus très stable et résistant, design droit et élégant, 2 cotées alternatives (1x coté panneau/1x coté étiquette), 2 plaques face-avant et séparateurs inclu, facilement convertible sur tiroir large avec livrable accessoires

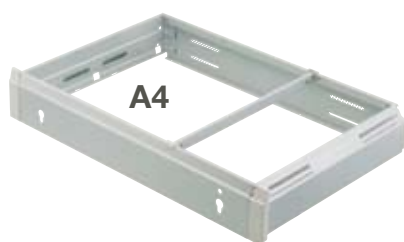

Typ Typ Type	Breite EB mm Width Largeur	Tiefe T mm Depth Profondeur	Art.-Nr. / Ref.No. / N° de réf. schwarz RAL 9005 black noir	G	VE
KHR 935.33 ECD	560/562	329	0123438.61		60
KHR 935.35 ECD	560/562	349	0122571.61		60



Typ Typ Type	Breite EB mm Width Largeur	Tiefe T mm Depth Profondeur	Art.-Nr. / Ref.No. / N° de réf. schwarz RAL 9005 black noir	G	VE
KHR 936.33 ECD	760/762	329	0123439.61		45
KHR 936.35 ECD	760/762	349	0124175.61		45
KHR 936.50 ECD	760/762	503	0122640.61		30

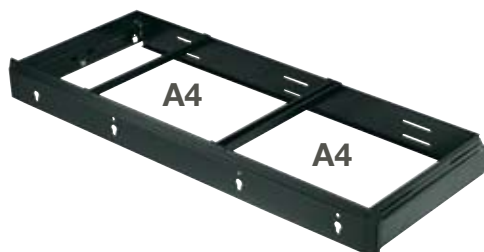

Typ Typ Type	Breite EB mm Width Largeur	Tiefe T mm Depth Profondeur	Art.-Nr. / Ref.No. / N° de réf. schwarz RAL 9005 black noir	G	VE
KHR 937.33 ECD	960/962	329	0123440.61		30
KHR 937.35 ECD	960/962	349	0122503.61		30

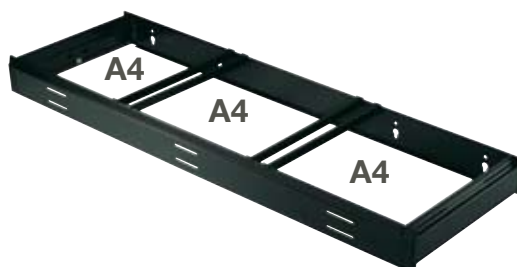

Typ Typ Type	Breite EB mm Width Largeur	Tiefe T mm Depth Profondeur	Art.-Nr. / Ref.No. / N° de réf. schwarz RAL 9005 black noir	G	VE
KHR 938.33 ECD	1160/1162	329	0123441.61		30
KHR 938.35 ECD	1160/1162	349	0122502.61		30

Differentialauszug MR 931

EB = 560-1162 mm
Progressive action slide / Coulisse différentielle
Width / Largeur 560-1162 mm

- Seitenstabiler Differentialauszug zu Kombi-Hängerrahmen
Bestückung mit Kunststoffrollen, Auszugweg 365, 350, 385, 530 mm
- Progressive action slide suitable for combo filing frame
equiped with plastic rollers, extension 365, 350, 385, 530 mm
- Coulisse différentielle avec haute stabilité latérale pour cadre dossiers suspendus
équipé avec galets en matière synthétique, ouverture 365, 350, 385, 530 mm

Befestigung mit Spaxschraube $\varnothing 4$ mm oder MERZ-Euroschraube ZK, vernickelt
Fastening method: chipboard screw $\varnothing 4$ mm or MERZ-Eurocrew ZK, nickel plated
Fixation par vis à tête fraisée $\varnothing 4$ mm ou Eurovis ZK MERZ, nickelées

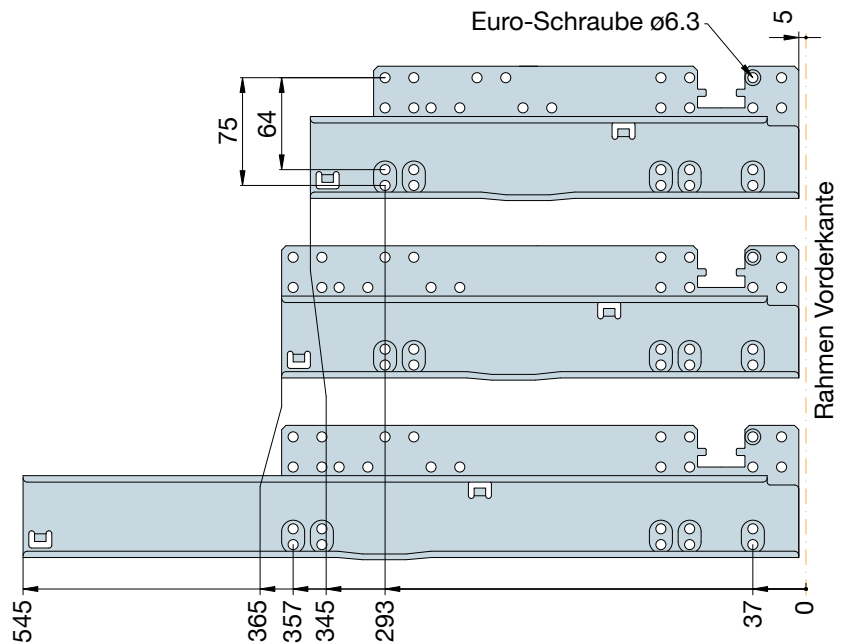
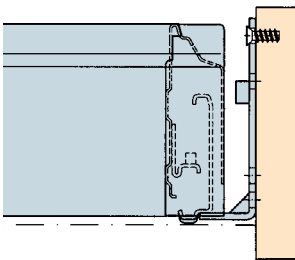

Belastbarkeit bis kg
Load capacity up to kg
Capacité de charge

60

Typ Type	Breite EB mm Width Largeur	Tiefe T mm Depth Profondeur	Art.-Nr. / Ref.No. / N° de réf. schwarz RAL 9005 black noir	G	VE
MR 931.34D ÜA	560-1160	345	0102570.61	2.39	10
MR 931.36D ECD	560-1160	365	0102504.61	2.57	10
MR 931.36D ÜA	560-1160	365	0123578.61	2.57	10
MR 931.34D ÜA	562-1162	345	0102496.61	2.39	10
MR 931.36D ECD	562-1162	365	0102453.61	2.57	10
MR 931.36D ÜA	562-1162	365	0123608.61	2.57	10
MR 931.54D ECD	562-1162	545	0103435.61	4.55	10

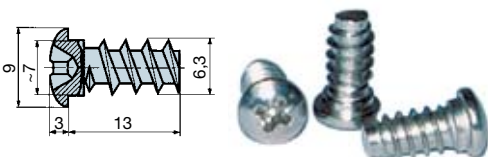

MERZ-Euroschraube ZK MERZ-Eurocrew Eurovis MERZ	Länge L mm Length Longueur	Art.-Nr. / Ref.No. / N° de réf. vernickelt nickel plated nickelées	G	VE
	13	0903936.02		500

MERZROLLER®

G Gewicht in kg pro Garnitur, Mittelwerte, ohne Verpackung
Weight in kg per set, average weight, without packing
Poids en kg par set, valeur moyenne sans emballage

VE Verpackungseinheit
packing unit
Unité d'emballage

Differentialauszug MR 931

EB = 580-1180 mm

Progressive action slide / Coulisse différentielle

Width / Largeur 580-1180 mm

- Seitenstabiler Differentialauszug zu Kombi-Hängerrahmen
Bestückung mit Kunststoffrollen, Auszugweg 365, 350, 385, 530 mm
- Progressive action slide suitable for combo filing frame
equiped with plastic rollers, extension 365, 350, 385, 530 mm
- Coulisse différentielle avec haute stabilité latérale pour cadre dossiers suspendus
équipé avec galets en matière synthétique, ouverture 365, 350, 385, 530 mm

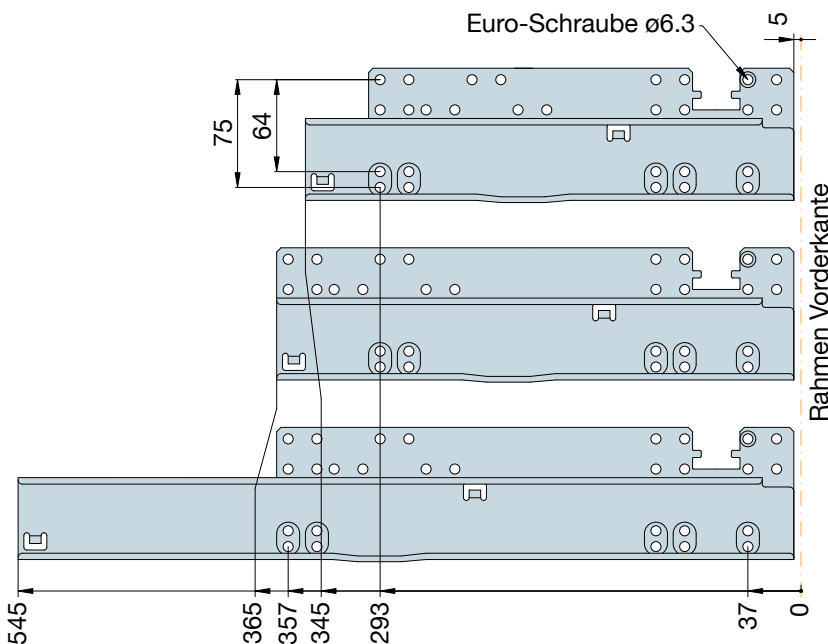

Befestigung mit Spaxschraube ø4 mm oder MERZ-Euroschraube ZK, vernickelt
Fastening method: chipboard screw ø4 mm or MERZ-Euro screw ZK, nickel plated
Fixation par vis à tête fraisée ø4 mm ou Eurovis ZK MERZ, nickelées

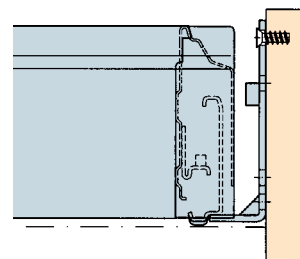

Typ	Breite EB mm	Tiefe T mm	Art.-Nr. / Ref.No. / N° de réf. schwarz RAL 9005	G	VE
Typ Type	Width Largeur	Depth Profondeur	black noir		
MR 931.34D ÜA	562-1162	345	0102496.61	2.39	10
MR 931.36D ECD	562-1162	365	0102453.61	2.57	10
MR 931.36D ÜA	562-1162	365	0123608.61	2.57	10
MR 931.54D ECD	562-1162	545	0103435.61	4.55	10

Belastbarkeit bis kg
Load capacity up to kg
Capacité de charge

60

- Distanzset 18 für EB=.80 BS+KHR Montageanleitung liegt bei
- Spacer Fitting instructions enclosed
- Espaceur Instructions de montage inclu

Typ	Breite EB mm	Tiefe T mm	Art.-Nr. / Ref.No. / N° de réf. schwarz RAL 9005	G	VE
Typ Type	Width Largeur	Depth Profondeur	black noir		
MR 713 / 931	580-1180		0904276.61		1
Sperre	580-1180		0904277.61		1

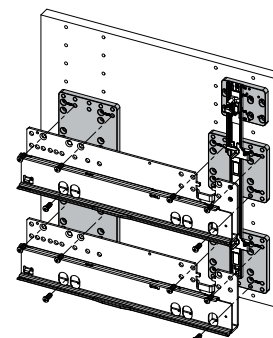

	Länge L mm	Art.-Nr. / Ref.No. / N° de réf. vernickelt	G	VE
MERZ-Euroschraube ZK MERZ-Euro screw Eurovis MERZ	Length Longueur	nickel plated nickelées		
	13	0903936.02		500

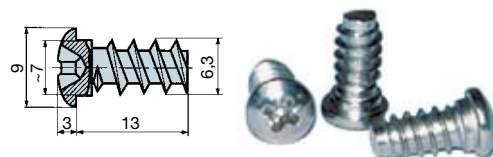

Mass- und Konstruktionsänderungen vorbehalten.
The manufacturer reserves the right to change the specification without notice.
Sous réserve de modifications de construction.

Zubehör zu Kombi-Hängerrahmen

Accessories / Accessoires



- Zentralverschluss-Anschlag für Breitschubladen und Kombi-Hängerrahmen
- Stop for central locking for wide metal drawer and combo filing frame
- Pièce de verrouillage central pour tiroir large et cadre dossiers suspendus

ZV-Anschlag SVS 3 Stop for central locking Pièce de verrouillage central	Breite EB mm Width Largeur	Art.-Nr. / Ref.No. / N° de réf. schwarz RAL 9005 black noir	G	VE
	LI 560-1162	0903733.61		1
	RE 560-1162	0903734.61		1
Blechschrabe / Screw / Vis à tôle	3.5 x 13	0902691.02		1



- Parallelführung für optimale Seitenstabilität bei Hängerrahmen
- Parallel guide for increased directional stability on combo filing frame
- Guide parallèle pour une stabilité latéral optimisée en cadre dossiers suspendus

Typ Typ Type	Breite EB mm Width Largeur	Tiefe T mm Depth Profondeur	Art.-Nr. / Ref.No. / N° de réf. schwarz RAL 9005 black noir	G	VE
MR 809.34 ÜA	562	345	0903442.61	0.14	25
MR 809.34 ÜA	762	345	0903443.61	0.15	25
MR 809.34 ÜA	962	345	0903444.61	0.17	25
MR 809.34 ÜA	1162	345	0903445.61	0.20	25
MR 809.36	562	365	0902781.61	0.14	25
MR 809.36	762	365	0902782.61	0.15	25
MR 809.36	962	365	0902783.61	0.17	25
MR 809.36	1162	365	0902784.61	0.20	25
MR 809.36 ÜA	562	365	0903574.61	0.14	25
MR 809.36 ÜA	762	365	0903575.61	0.15	25
MR 809.36 ÜA	962	365	0903576.61	0.17	25
MR 809.36 ÜA	1162	365	0903577.61	0.20	25
MR 809.54	762	545	0903390.61	0.19	25

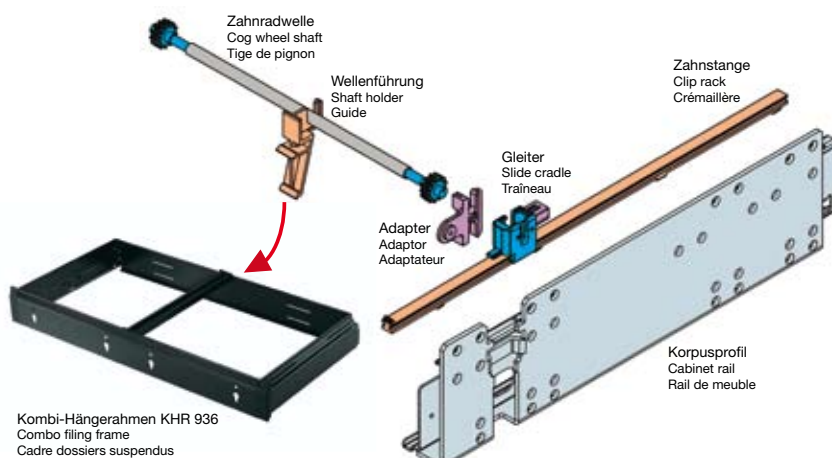

Zubehör zu Kombi-Hängerahmen

Accessories / Accessoires

- Einzugsdämpfung ECD BS+KHR Montageanleitung liegt bei
- Damper / Easy close device Fitting instructions enclosed
- Amortiseur Instructions de montage inclu

Typ	Breite EB mm	Tiefe T mm	Art.-Nr. / Ref.No. / N° de réf. schwarz RAL 9005 black noir	G	VE
Typ Type	Width Largeur	Depth Profondeur			
Set ECD BS+KHR	562-1162		0904089.61		1
Mitnehmer links			2182001.61		
Mitnehmer rechts			2182002.61		

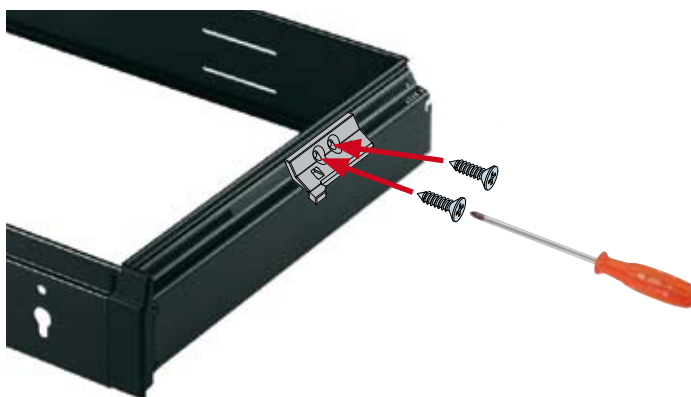
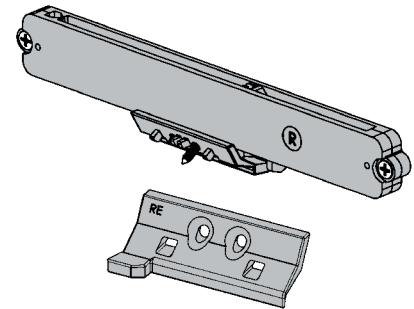

- Beide Mitnehmer mit den Senkschrauben sichern
- Secure both trigger plates with a screw
- Vissez les deux clips pour assurer la fixation

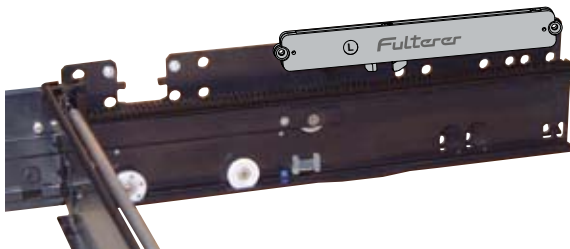

- U-Profil linke Seite
- Cabinet rail left side
- Profile de meuble côté à gauche

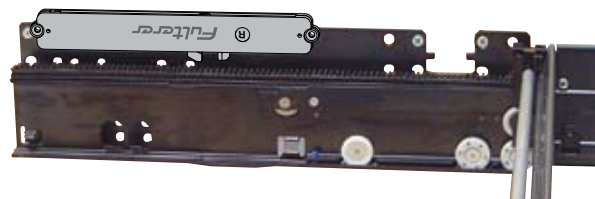

- U-Profil rechte Seite
- Cabinet rail right side
- Profile de meuble côté à droite

- Boden zu Kombi-Hängerahmen, für den Umbau zur Breitschublade
- Bottom inlay for combo filing frame KHR
- Sol à encastrer pour cadre suspendu KHR



Typ	Breite EB mm	Tiefe T mm	Art.-Nr. / Ref.No. / N° de réf. schwarz RAL 9005 black noir	G	VE
Typ Type	Width Largeur	Depth Profondeur			
Boden 935.33	562	329	0903498.61		4
Boden 936.33	762	329	0903499.61		4
Boden 937.33	962	329	0903500.61		4
Boden 938.33	1162	329	0903501.61		4
Boden 935.35	562	349	0902510.61		4
Boden 936.35	762	349	0902419.61		4
Boden 937.35	962	349	0902511.61		4
Boden 938.35	1162	349	0902512.61		4
Boden 936.54	762	503	0903349.61		4

- Rasterschiene zu Kombi-Hängerahmen, für den Umbau zur Breitschublade
- Side cover plate for combo filing frame KHR
- Profile latérale pour cadre suspendu KHR



Typ	Breite EB mm	Tiefe T mm	Art.-Nr. / Ref.No. / N° de réf. schwarz RAL 9005 black noir	G	VE
Typ Type	Width Largeur	Depth Profondeur			
Rasterschiene 935	562		0902509.61		2
Rasterschiene 936	762		0902420.61		2
Rasterschiene 937	962		0902507.61		2
Rasterschiene 938	1162		0902508.61		2

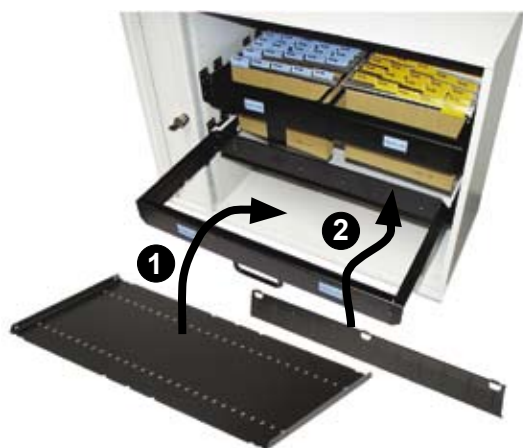

- Umbau vom Kombi-Hängerahmen zur Breitschublade
 1. Boden in Hängerahmen einlegen
 2. Rasterschiene in Front und Rückwand einclippen
- Conversion from filing frame to drawer
 1. Insert bottom inlay into filing frame
 2. Insert side cover plates in front and back of frame
- Conversion du cadre à tiroir
 1. Encastrer le sol au cadre suspendu
 2. Insérer les profils latérales dans le cadre

Zubehör zu Kombi-Hängerahmen

Metall

Accessories / Accessoires

Metal / Métal

Zwischensteg KHR Hanging file rail Séparateur pour dossier suspendu	Dimension mm	Art.-Nr. / Ref.No. / N° de réf. schwarz RAL 9005 black noir	G	VE
	IT=306	0903497.61	0.14	1
	IT=326	0902418.61	0.15	1
	IT=480	0902657.61	0.21	1

Zwischensteg KHR hoch Hanging file rail Séparateur pour dossier suspendu	Dimension mm	Art.-Nr. / Ref.No. / N° de réf. schwarz RAL 9005 black noir	G	VE
	IT=306	0903436.61		1
	IT=326	0902988.61	0.54	1
	IT=480	0903333.61		1

- Blendenabstützung fix für hohe Frontblenden zu Kombi-Hängerahmen
- Front panel brace for combo filing frame with high front panel
- Support de panneau pour cadre dossiers suspendus avec haute panneau frontal

Blendenabstützung fix Front panel brace Support de panneau frontal	Dimension mm	Art.-Nr. / Ref.No. / N° de réf. schwarz RAL 9005 black noir	G	VE
			0902421.61	

Mappenhalter KHR File holder clamp Maintien de dossiers	Dimension mm	Art.-Nr. / Ref.No. / N° de réf. schwarz RAL 9005 black noir	G	VE
	173x60	0902452.61	0.13	1

- KHR 936.35 mit Mappenhalter KHR
- KHR 936.35 with file holder clamp
- KHR 936.35 avec maintien de dossiers





Materialschale KHR Sliding tray Bac à pousser	Dimension mm	Art.-Nr. / Ref.No. / N° de réf. schwarz RAL 9005 black noir	G	VE
	222 x 328	0902426.61		64

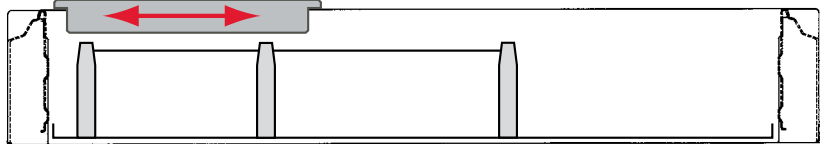

Utensilien-Einsatzschale Pencil tray Bac pour ustensiles	Dimension mm	Art.-Nr. / Ref.No. / N° de réf. schwarz RAL 9005 black noir	G	VE
	326 x 326	0901478.61	0.41	25



Papier-Einsatzschale Paper tray Bac pour papier	Dimension mm	Art.-Nr. / Ref.No. / N° de réf. schwarz RAL 9005 black noir	G	VE
	326 x 326	0901477.61	0.35	25



- 3 Einsatzschalen pro Schublade
- 3 trays per drawer
- 3 bacs par tiroir

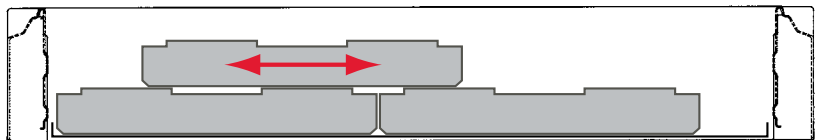

- KHR 936.35 mit Materialschale KHR und Metallunterteiler
- KHR 936.35 with sliding tray and metal subdivider elements
- KHR 936.35 avec bac à pousser et subdiviseurs en métal

Accessories / Accessoires

Metal / Métal

	Dimension mm	Art.-Nr. / Ref.No. / N° de réf. schwarz RAL 9005 black noir	G	VE
Trennschied Metall UB+KHR Metal system divider Diviseur	306 x 65	0902739.61		1
	330 x 65	0902024.61	0.26	1
	479 x 65	0903357.61		1



	Dimension mm	Art.-Nr. / Ref.No. / N° de réf. schwarz RAL 9005 black noir	G	VE
Metallunterteiler Metal subdivider elements Subdiviseurs en métal	A5, 226	0901731.61		1
	A6, 167	0901732.61	0.11	1
	A7, 109	0901733.61		1

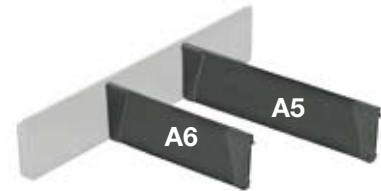

- KHR 936.35 mit Trennschied Metall UB+KHR und Metallunterteiler
- KHR 936.35 with metal system divider and metal subdivider elements
- KHR 936.35 avec diviseur et subdiviseurs en métal

- Karteitrog und Schwenkblatt siehe Seite 43
- Mounting file track and swivel insert see page 43
- Bac à fiches et plaque coulissante voir la page 43

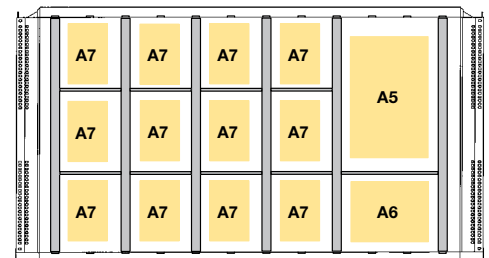
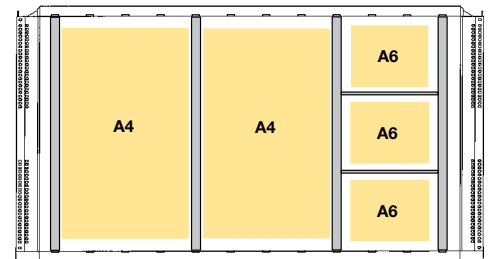

	Dimension mm	Art.-Nr. / Ref.No. / N° de réf. schwarz RAL 9005 black noir	G	VE
Schräglage KHR Paper plate Casier pour papier	324 x 240	0903126.61	0.67	5

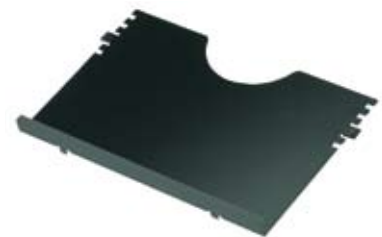

- KHR 936.35 mit Schräglage KHR
- KHR 936.35 with paper plate
- KHR 936.35 avec casier pour papier

Klappbeschlag MR 136

EB = 760-1162 mm
Flipper door / Coulisse pliante pour couvercles ou clapets
Width / Largeur 760-1162 mm



Belastbarkeit bis kg
Load capacity up to kg
Capacité de charge

7

Befestigung mit Spaxschraube $\varnothing 3.5$ mm oder MERZ-Euroschraube, vernickelt
Fastening method: chipboard screw $\varnothing 3.5$ mm or MERZ-Eurocrew, nickel plated
Fixation par vis à tête fraisée $\varnothing 3.5$ mm ou Eurovis MERZ, nickelées

- Klappbeschlag für Klappentiefen von 380 - 400 mm (Führungslänge 365 mm)
Wahlweise mit und ohne Parallelführung einsetzbar
Ohne Parallelführung besteht keine Möbelbreitenabhängigkeit
Mit Parallelführung sind Schrankbreiten von 800 - 1200 möglich
Blendenaufnahme als reine Schraubbefestigung (Höhenverstellung möglich)
- Flipper door for lid depths of 380 - 400 mm (slide length 365 mm)
Alternatively with or without parallel guide (with parallel guides for widths of 800 - 1200 mm, without parallel guide independent of width)
Front panel fastening with screws (height adjustment with elongated holes)
- Coulisse pliante pour couvercles ou clapets avec une profondeur de 380 - 400 mm (longueur de guidage 365 mm)
Facultativement applicable avec ou sans guide parallèle
Avec guide parallèle: des profondeurs de 800 - 1200 mm sont possible
Sans guide parallèle: pas de dépendance du largeur du meuble
Fixation du couvercles/clapets pour visser (hauteur variable)

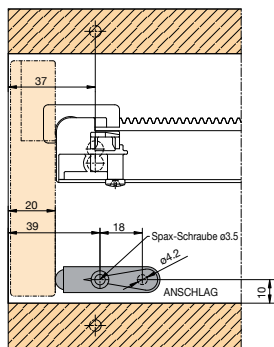
Typ Type	Breite EB mm Width Largeur	Tiefe T mm Depth Profondeur	Art.-Nr. / Ref.No. / N° de réf. schwarz RAL 9005 black noir	G	VE
MR 136.36 HE50		379	0103524.60		25
MR 136.36 HE64		379	0103528.60		25
Welle 737	760		0903570.03		25
Welle 937	960		0903527.03		25
Welle 1137	1160		0903571.03		25
Welle 739	762		0903529.03		25
Welle 939	962		0903530.03		25
Welle 1139	1162		0903531.03		25



Ansschlag Stop Butée de fermeture	Länge L mm Length Longueur	Art.-Nr. / Ref.No. / N° de réf. schwarz RAL 9005 black noir	G	VE
		0903613.00		50

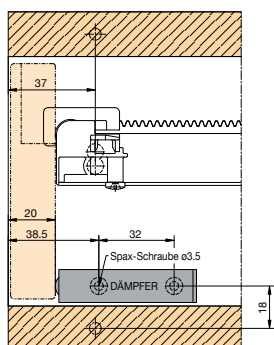

Dämpfer Shockabsorber Amortisseur	Länge L mm Length Longueur	Art.-Nr. / Ref.No. / N° de réf. grau RAL 7035 grey gris	G	VE
		0903614.00		50

Klappbeschlag MR 136

EB = 760-1162 mm

Flipper door / Coulisse pliante pour couvercles ou clapets

Width / Largeur 760-1162 mm

Höheneinheit HE50

Unit of height / L'unité de hauteur

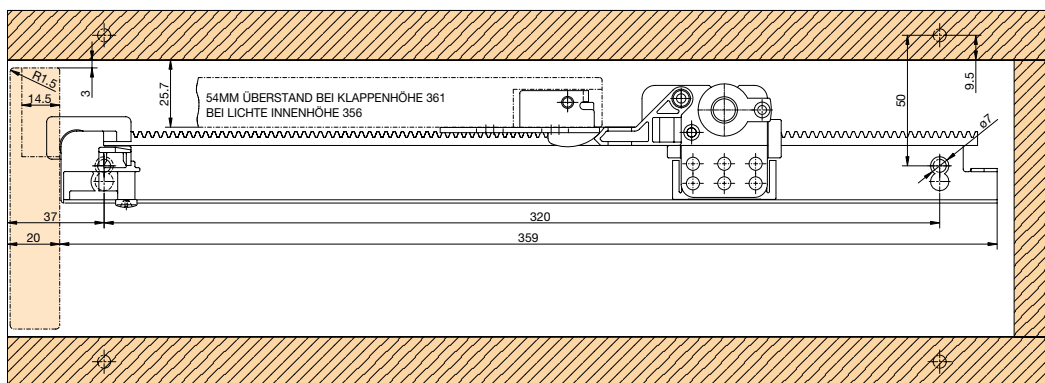
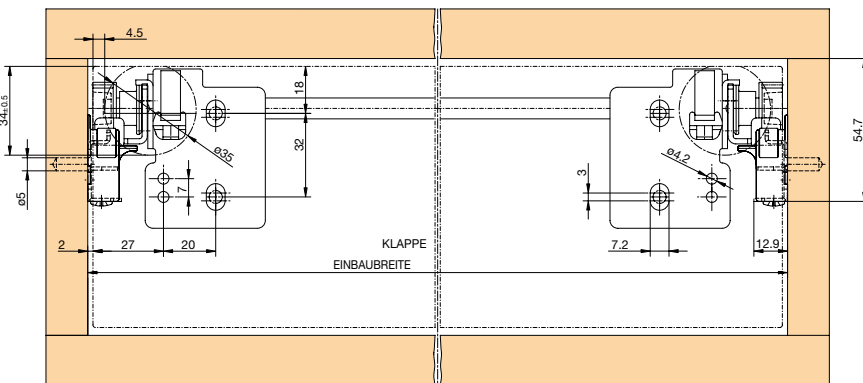

Höheneinheit HE64

Unit of height / L'unité de hauteur

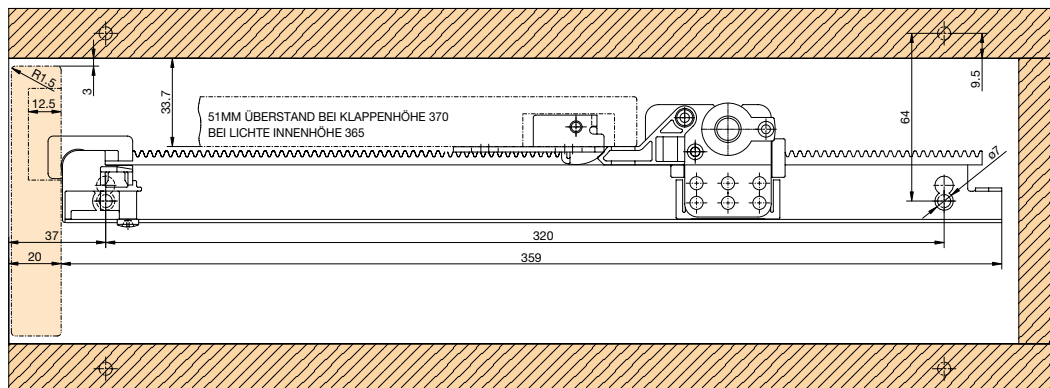
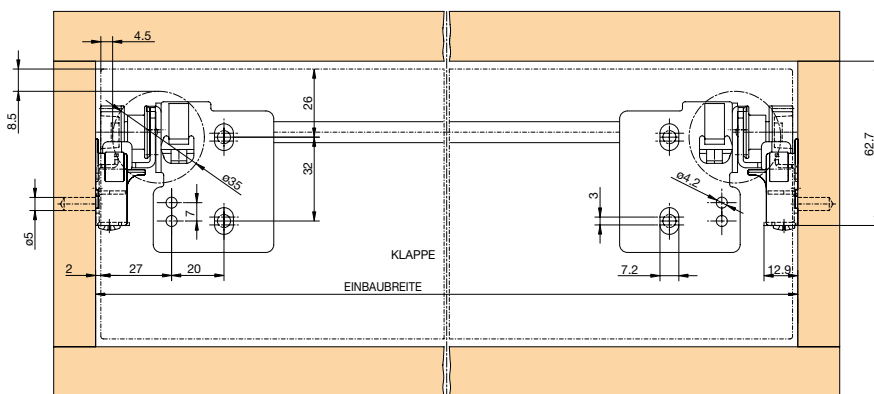

Mass- und Konstruktionsänderungen vorbehalten.
The manufacturer reserves the right to change the specification without notice.
Sous réserve de modifications de construction.