

## Inhalt Schrank

### Contents cabinet / Sommaire armoire

#### Konstruktions-Information / Design data / Informations sur la construction

		Seite / Page / Page
Karteischränk	Lochreihe 25 mm, EB=762 mm	40
	Lochreihe 32 mm, EB=762 mm	41

#### Breitschublade / Wide metal drawer / Tiroir large

Breitschublade	ZMS 941, 943	EB=562/762 mm	42
Belegschublade	MB 941, 943	EB=562/762 mm	43

#### Schubladenführungen / Drawer slides / Coulisses des tiroirs

Differentialauszug	MR 713	EB=562/762 mm	44
Differentialauszug	MR 713	EB=580/780 mm	45

#### Zubehör zu Breitschublade / Accessories / Accessoires

Parallelführung	MR 810	EB=562-762 mm	46
Einzugsdämpfer	ECD		47

#### Organisationsmaterial zu Breitschublade / Accessories / Accessoires

Kunststoff			48
Metall			50

#### Konstruktions-Information / Design data / Informations sur la construction

Registraturschränk	Lochreihe 25 mm, EB=762 mm	52
	Lochreihe 32 mm, EB=762 mm	53

#### Kombi-Hängerahmen / Combo filing frame / Cadre dossiers suspendus

Kombi-Hängerahmen	KHR 935	EB= 560/ 562 mm	54
Kombi-Hängerahmen	KHR 936	EB= 760/ 762 mm	
Kombi-Hängerahmen	KHR 937	EB= 960/ 962 mm	
Kombi-Hängerahmen	KHR 938	EB=1160/1162 mm	

#### Schubladenführungen / Drawer slides / Coulisses des tiroirs

Differentialauszug	MR 931	EB=560-1162 mm	56
Differentialauszug	MR 931	EB=580-1180 mm	57

#### Zubehör zu Kombi-Hängerahmen / Accessories / Accessoires

Parallelführung	MR 809	EB=562-1162 mm	58
Einzugsdämpfer	ECD		59
Metall			60

#### Organisationsmaterial zu KHR / Accessories / Accessoires

Kunststoff			62
Metall			63

#### Klappbeschlag / Flipper door / Coulisse pliante pour couvercles ou clapets

Klappbeschlag	MR 136	EB=760-1162 mm	64
---------------	--------	----------------	----

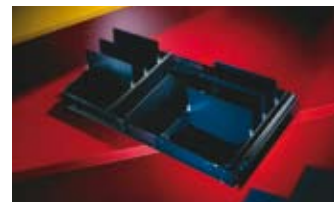

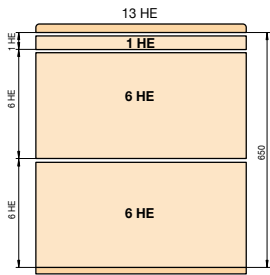

### Höheneinheiten HE Raster 25 mm

1	HE =	50 mm
3	HE =	150 mm
6	HE =	300 mm
13	HE =	650 mm
19	HE =	950 mm

- Die Zeichnungen zeigen Beispiele für die Konstruktion eines Karteischranks. Basis sind Lochreihen im Abstand von 25 mm (vertikal 25 mm, horizontal 32 mm). Der Karteischränk ist in der Höhe variabel und somit auch die Anzahl der HE. Die Blende ist ein Mehrfaches der Höheneinheit (HE) - 3 mm Luft.
- Illustration of a card index case. Based on a pattern of holes every 25 mm vertically and 32 mm horizontally. The card index case is variable in the total height, therefore also the number of the units of height HE. The front panel is a multiple of the unit of height (HE) minus 3 mm for space.
- Les dessins montrent des exemples de constructions d'armoires pour fichiers. Ils ont pour base des rangées de perforations espacées de 25 mm (verticalement 25 mm et horizontalement 32 mm). L'armoire pour fichiers est variable en hauteur et donc également en nombre d'unités dans le sens vertical HE. Le panneau frontal est un multiple de l'unité de hauteur (HE) moins 3 mm de jeu.

Typ	Breite EB mm	Mass A mm	Mass B mm	Mass D mm
Typ Type	Width Largeur	Measure Mesure	Measure Mesure	Measure Mesure
ZMS 941.35	562	376		70
ZMS 941.51	562	376		70
ZMS 943.35	762	128	224	70
ZMS 943.51	762	128	224	70

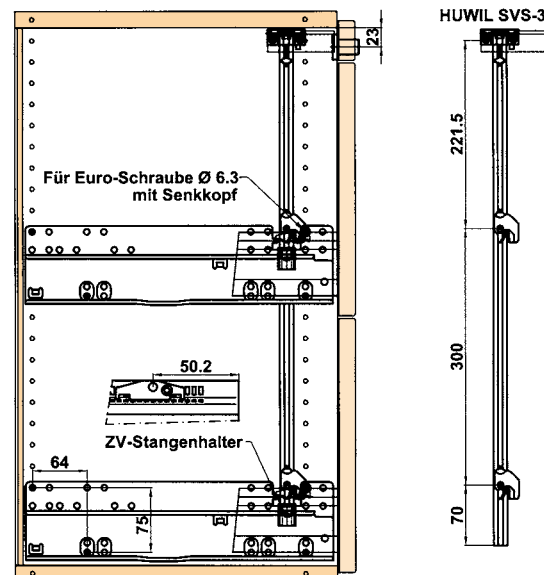
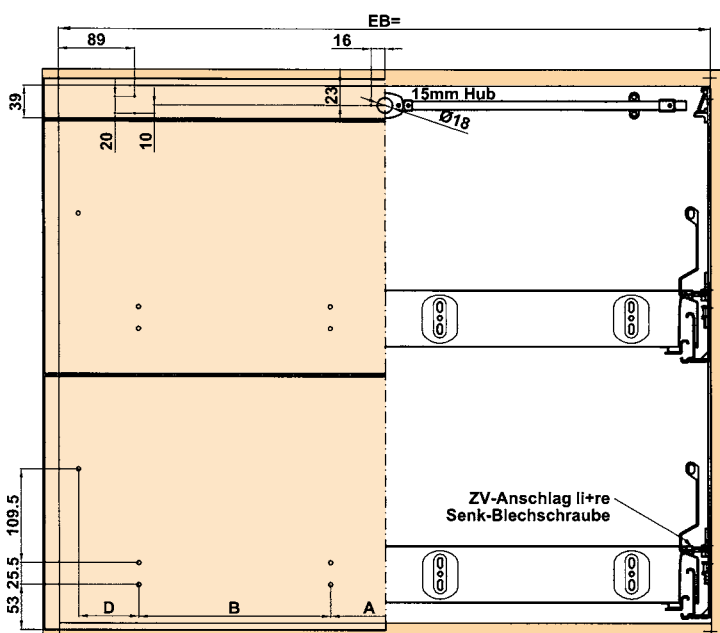
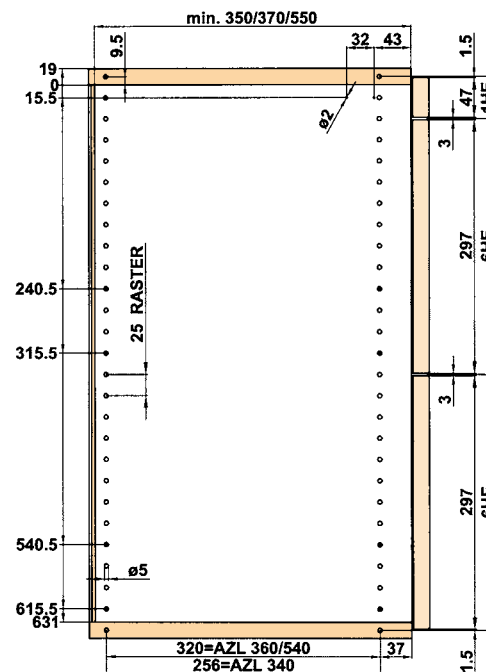

**Design data / Informations sur la construction**

**Pattern of holes / Perf. tous les 32 mm**

- Die Zeichnungen zeigen Beispiele für die Konstruktion eines Karteischranks. Basis sind Lochreihen im Abstand von 32 mm (vertikal und horizontal). Der Karteischränk ist in der Höhe variabel und somit auch die Anzahl der HE. Die Blende ist ein Mehrfaches der Höheneinheit (HE) -3 mm Luft.
- Illustration of a card index case. Based on a pattern of holes every 32 mm vertically and 32 mm horizontally. The card index case is variable in the total height, therefore also the number of the units of height HE. The front panel is a multiple of the unit of height (HE) minus 3 mm for space.
- Les dessins montrent des exemples de constructions d'armoires pour fichiers. Ils ont pour base des rangées de perforations espacées de 32 mm (verticalement et horizontalement). L'armoire pour fichiers est variable en hauteur et donc également en nombre d'unités dans le sens vertical HE. Le panneau frontal est un multiple de l'unité de hauteur (HE) moins 3 mm de jeu.

**Höheneinheiten HE  
Raster 32 mm**

1	HE = 64 mm
2,5	HE = 160 mm
5	HE = 320 mm
11	HE = 704 mm
16	HE = 1024 mm

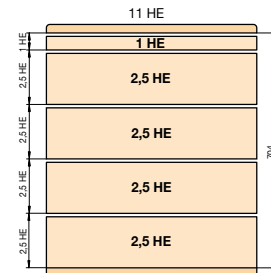

Typ Type	Breite EB mm Width Largeur	Mass A mm Measure Mesure	Mass B mm Measure Mesure	Mass D mm Measure Mesure
ZMS 941.35	562	376		
ZMS 941.51	562	376		
ZMS 943.35	762	128	224	
ZMS 943.51	762	128	224	

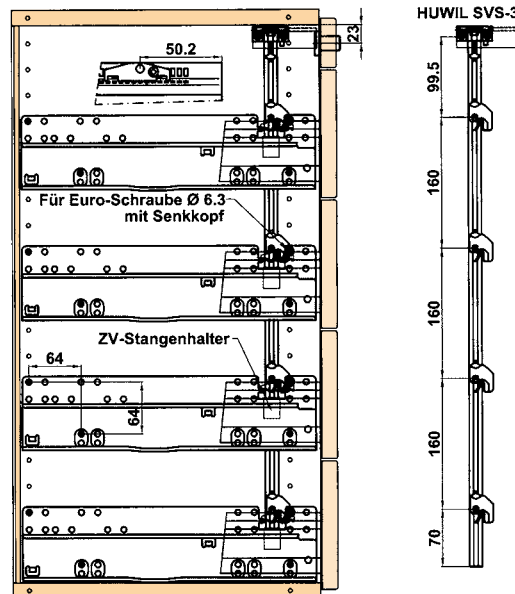
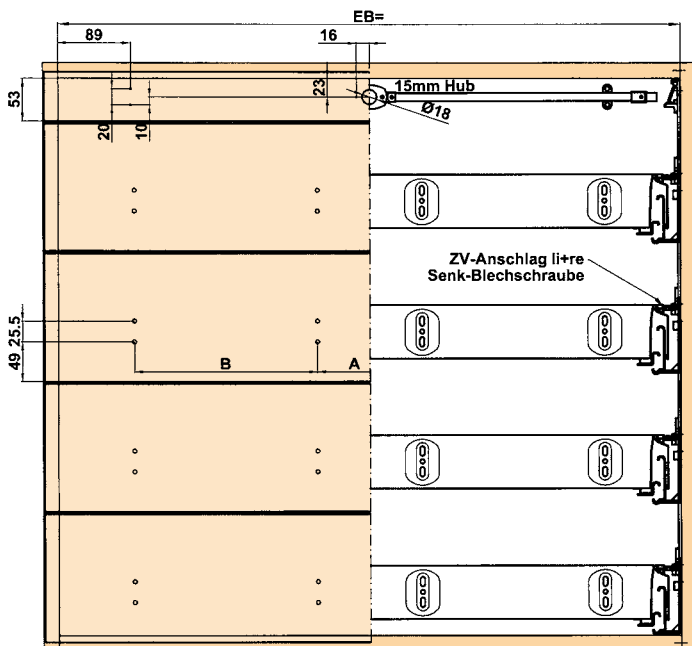
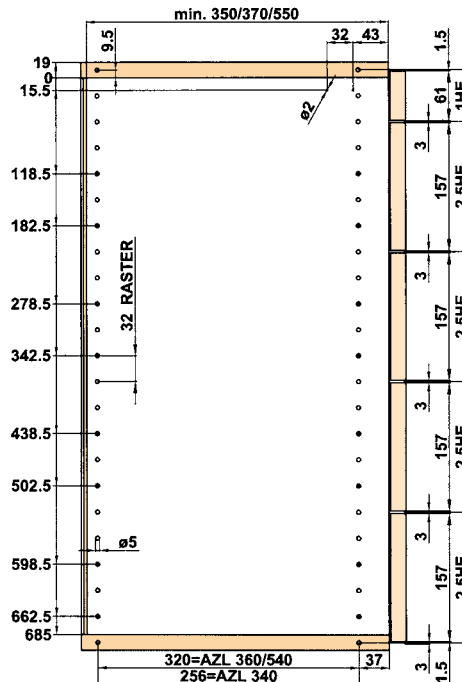

Mass- und Konstruktionsänderungen vorbehalten.  
The manufacturer reserves the right to change the specification without notice.  
Sous réserve de modifications de construction.

## Breitschublade ZMS 941, 943

EB = 562/762 mm

Wide metal drawer / Tiroir large

Width / Largeur 562/762 mm

- Stabile, verwindungssteife Breitschublade, formschönes, geradliniges Design
- Stable, torsion-resistant wide metal drawer, elegant, straight design
- Tiroir large très stable et résistant, design droit et élégant

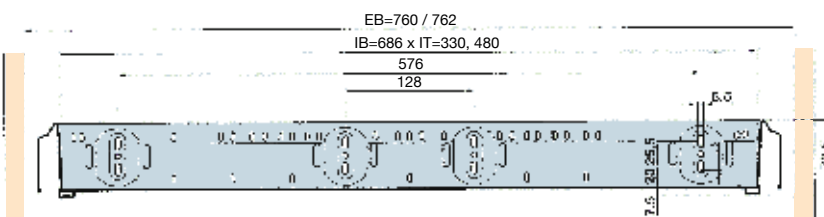
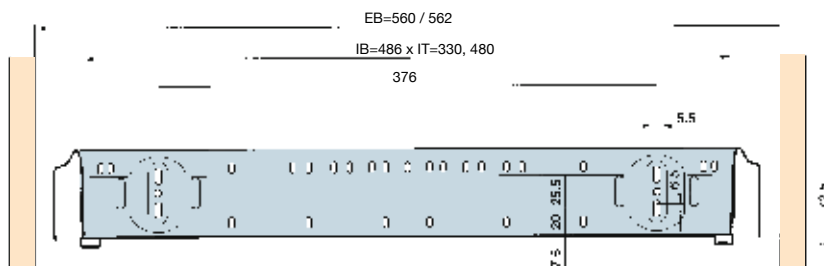

Typ Type	Breite EB mm Width Largeur	Tiefe T mm Depth Profondeur	Art.-Nr. / Ref.No. / N° de réf. <b>schwarz RAL 9005</b> black noir	G	VE
ZMS 941.35 ECD	562	351	<b>0123459.61</b>		80
ZMS 941.51 ECD	562	513	<b>0123460.61</b>		40
ZMS 943.35 ECD	762	351	<b>0123461.61</b>		60
ZMS 943.51 ECD	762	513	<b>0123462.61</b>		40



- Breitschublade ZMS 943.35 mit Frontblende, Einsatzschale und HR-Einsatz A4
- Wide metal drawer with cover plate, pencil tray and hanging file frame
- Tiroir large avec panneau face-avant, bac pour ustensiles et cadre pour dossiers

# Belegschublade MB 941, 943

EB = 562/762 mm

Banking drawer / Tiroir large

Width / Largeur 562/762 mm

- Verwindungssteife Belegschublade mit verdeckter Führung, vorne mit Fächern für Belege, hinterer Teil organisierbar
- Stable, torsion-resistant banking drawer
- Tiroir large très stable et résistant, pour documents, billets et quittances

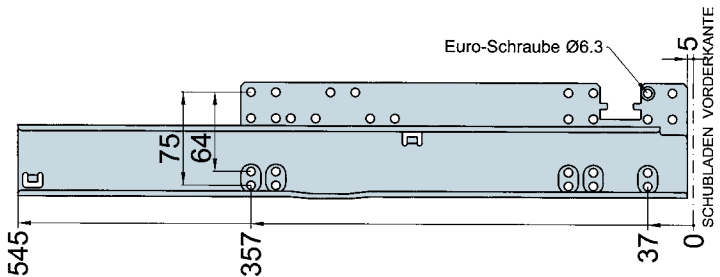
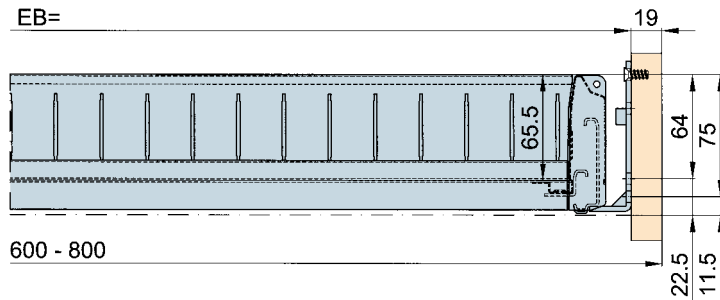

Typ	Breite EB mm	Tiefe T mm	Art.-Nr. / Ref.No. / N° de réf. schwarz RAL 9005 black noir	G	VE
Typ Type	Width Largeur	Depth Profondeur			
MB 941.55D ECD	562	545	<b>0103954.61</b>		1
MB 943.55D ECD	762	545	<b>0103955.61</b>		1

Belastbarkeit bis kg  
Load capacity up to kg  
Capacité de charge

**60**

# Differentialauszug MR 713

**EB = 562/762 mm**
**Progressive action slide / Coulisse différentielle**
**Width / Largeur 562/762 mm**

- Seitenstabiler Differentialauszug zu Breitschublade, für aufliegende Montage, Bestückung mit Kunststoffrollen, Auszugweg 350, 530 mm
- Progressive action slide suitable for wide metal drawer, for bottom mounting, equiped with plastic rollers, extension 350, 530 mm
- Coulisse différentielle avec haute stabilité latérale pour tiroir large, pour montage en base de tiroir, équipé avec galets en matière synthétique, ouverture 350, 530 mm

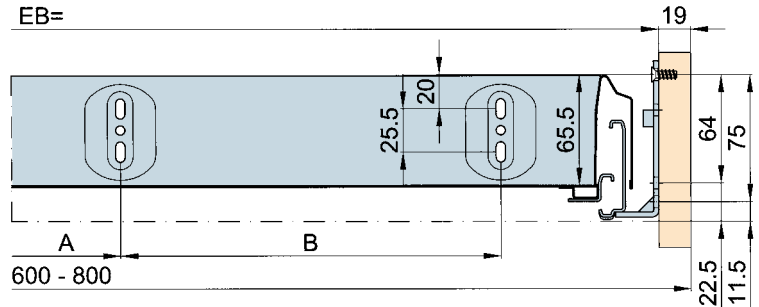

Befestigung mit Spaxschraube  $\varnothing 4$  mm oder MERZ-Euroschraube ZK, vernickelt  
 Fastening method: chipboard screw  $\varnothing 4$  mm or MERZ-Euro screw ZK, nickel plated  
 Fixation par vis à tête fraisée  $\varnothing 4$  mm ou Eurovis ZK MERZ, nickelées

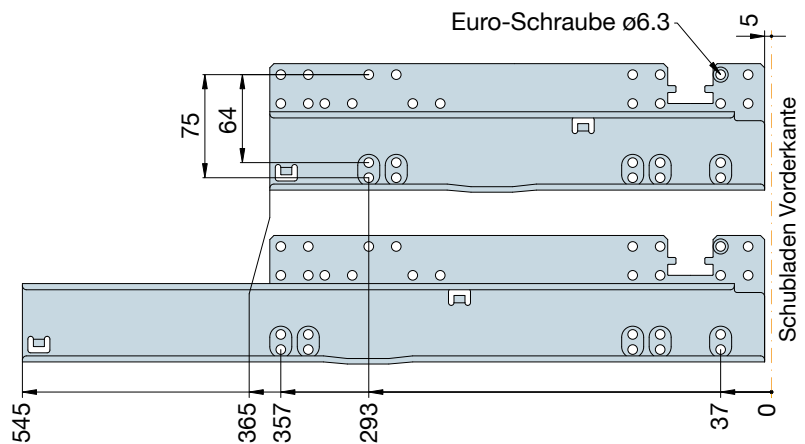

Belastbarkeit bis kg  
 Load capacity up to kg  
 Capacité de charge

**60**

Typ Type	Breite EB mm Width Largeur	Tiefe T mm Depth Profondeur	Art.-Nr. / Ref.No. / N° de réf. <b>schwarz RAL 9005</b> black noir	G	VE
MR 713.36D ECD	562/762	365	<b>0103456.61</b>	2.57	8
MR 713.54D ECD	562/762	545	<b>0103455.61</b>	4.55	8

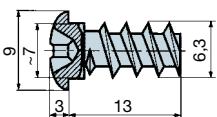

MERZ-Euroschraube ZK MERZ-Euro screw Eurovis MERZ	Länge L mm Length Longueur	Art.-Nr. / Ref.No. / N° de réf. <b>vernickelt</b> nickel plated nickelées	G	VE
	13	<b>0903936.02</b>		500

# MERZROLLER®

**G** Gewicht in kg pro Garnitur, Mittelwerte, ohne Verpackung  
 Weight in kg per set, average weight, without packing  
 Poids en kg par set, valeur moyenne sans emballage

**VE** Verpackungseinheit  
 packing unit  
 Unité d'emballage

# Differentialauszug MR 713

EB = 580/780 mm

Progressive action slide / Coulisse différentielle

Width / Largeur 580/780 mm

- Seitenstabiler Differentialauszug zu Breitschublade, für aufliegende Montage, Bestückung mit Kunststoffrollen, Auszugsweg 350, 530 mm
- Progressive action slide suitable for wide metal drawer, for bottom mounting, equipped with plastic rollers, extension 350, 530 mm
- Coulisse différentielle avec haute stabilité latérale pour tiroir large, pour montage en base de tiroir, équipé avec galets en matière synthétique, ouverture 350, 530 mm

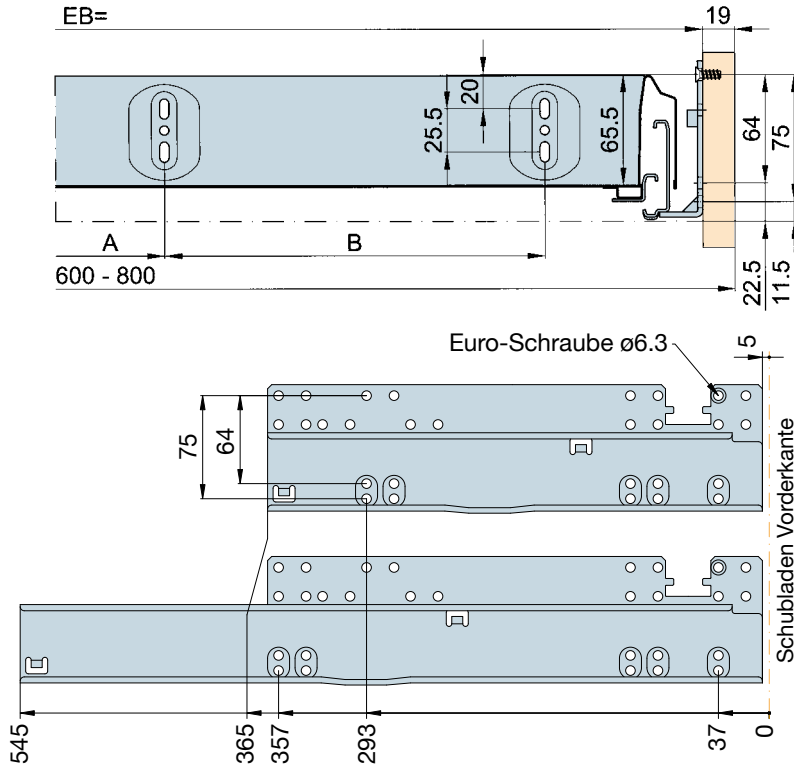

Befestigung mit Spaxschraube ø4 mm oder MERZ-Euroschraube ZK, vernickelt  
 Fastening method: chipboard screw ø4 mm or MERZ-Euro screw ZK, nickel plated  
 Fixation par vis à tête fraisée ø4 mm ou Eurovis ZK MERZ, nickelées

Typ Type	Breite EB mm Width Largeur	Tiefe T mm Depth Profondeur	Art.-Nr. / Ref.No. / N° de réf. <b>schwarz RAL 9005</b> black noir	G	VE
MR 713.36D ECD	562/762	365	<b>0103456.61</b>	2.57	8
MR 713.54D ECD	562/762	545	<b>0103455.61</b>	4.55	8

Belastbarkeit bis kg  
 Load capacity up to kg  
 Capacité de charge **60**

- Distanzset 18 für EB=.80 BS+KHR Montageanleitung liegt bei
- Spacer Fitting instructions enclosed
- Espaceur Instructions de montage inclu

Typ Type	Breite EB mm Width Largeur	Tiefe T mm Depth Profondeur	Art.-Nr. / Ref.No. / N° de réf. <b>schwarz RAL 9005</b> black noir	G	VE
MR 713 / 931	580/780		<b>0904276.61</b>		1
Sperre	580/780		<b>0904277.61</b>		1

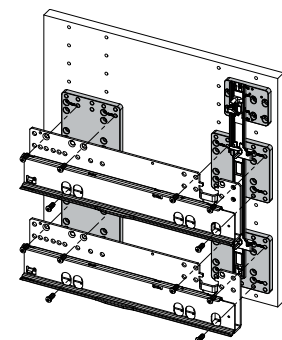

	Länge L mm Length Longueur	Art.-Nr. / Ref.No. / N° de réf. <b>vernickelt</b> nickel plated nickelées	G	VE
<b>MERZ-Euroschraube ZK</b> MERZ-Euro screw Eurovis MERZ	13	<b>0903936.02</b>		500

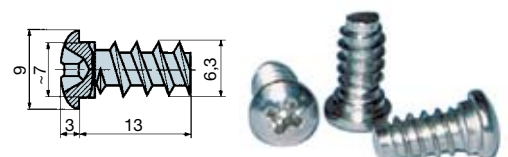

Mass- und Konstruktionsänderungen vorbehalten.  
 The manufacturer reserves the right to change the specification without notice.  
 Sous réserve de modifications de construction.

## Zubehör zu Breitschublade

### Accessories / Accessoires



- Zentralverschluss-Anschlag für Breitschubladen und Kombi-Hängerrahmen
- Stop for central locking for wide metal drawer and combo filing frame
- Pièce de verrouillage central pour tiroir large et cadre dossiers suspendus

	Breite EB mm Width Largeur	Art.-Nr. / Ref.No. / N° de réf. <b>schwarz RAL 9005</b> black noir	G	VE
<b>ZV-Anschlag SVS 3</b> Stop for central locking Pièce de verrouillage central	LI 560-1162	<b>0903733.61</b>		1
	RE 560-1162	<b>0903734.61</b>		1
<b>Blechschrabe</b> / Screw / Vis à tôle	3.5 x 13	<b>0902691.02</b>		1

- Parallelführung für optimale Seitenstabilität bei Breitschubladen, auch in ausgefahrenem Zustand, nachträglicher Einbau möglich
- Parallel guide for increased directional stability on wide metal drawers
- Guide parallèle pour une stabilité latéral optimée en tiroir large



Typ Typ Type	Breite EB mm Width Largeur	Tiefe T mm Depth Profondeur	Art.-Nr. / Ref.No. / N° de réf. <b>schwarz RAL 9005</b> black noir	G	VE
MR 810.36	562	365	<b>0903463.61</b>	0.15	25
MR 810.36 ÜA	562	365	<b>0903465.61</b>	0.16	25
MR 810.54	562	545	<b>0903467.61</b>	0.18	25
MR 810.36	762	365	<b>0903464.61</b>	0.16	25
MR 810.36 ÜA	762	365	<b>0903466.61</b>	0.17	25
MR 810.54	762	545	<b>0903468.61</b>	0.19	25

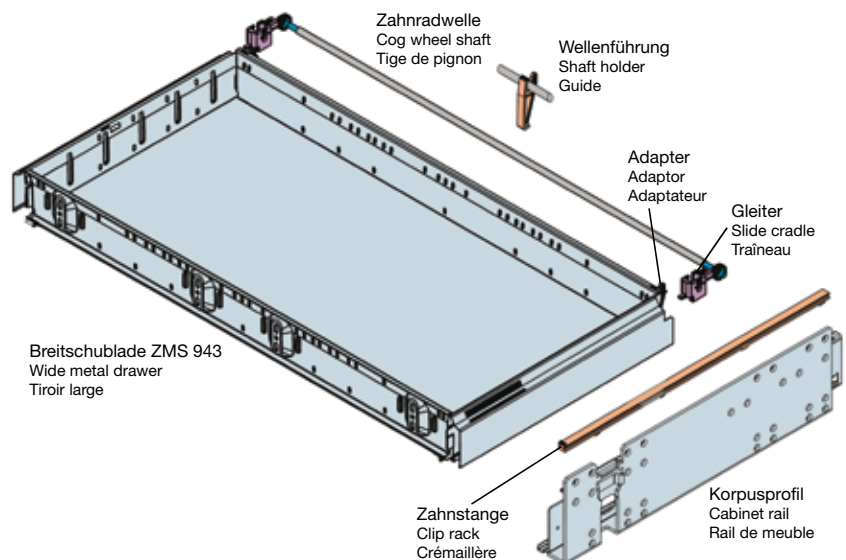

## Zubehör zu Breitschublade

### Accessories / Accessoires

- Frontblende für Schubladen hinter Türen oder Rolläden
- Cover plate for drawers behind doors and roller-blinds
- Panneau face-avant pour tiroirs derrière des portes et volets roulant

Typ Type	Breite EB mm Width Largeur	Tiefe T mm Depth Profondeur	Art.-Nr. / Ref.No. / N° de réf. <b>schwarz RAL 9005</b> black noir	G	VE
Frontblende ZMS 941	562		<b>0903666.61</b>		1
Frontblende ZMS 943	762		<b>0902978.61</b>		1

- Blendenabstützung fix für hohe Frontblenden zu Breitschublade
- Front panel brace for wide metal drawers with high front panel
- Support de panneau pour tiroirs large avec haute panneau frontal

Dimension mm	Art.-Nr. / Ref.No. / N° de réf. <b>schwarz RAL 9005</b> black noir	G	VE
<b>Blendenabstützung fix</b> Front panel brace Support de panneau frontal	<b>0902421.61</b>		1

- Einzugsdämpfung ECD BS+KHR      Montageanleitung liegt bei
- Damper / Easy close device      Fitting instructions enclosed
- Amortiseur      Instructions de montage inclu

Typ Type	Breite EB mm Width Largeur	Tiefe T mm Depth Profondeur	Art.-Nr. / Ref.No. / N° de réf. <b>schwarz RAL 9005</b> black noir	G	VE
Set ECD BS+KHR	562-1162		<b>0904089.61</b>		1
Mitnehmer links			<b>2182001.61</b>		
Mitnehmer rechts			<b>2182002.61</b>		

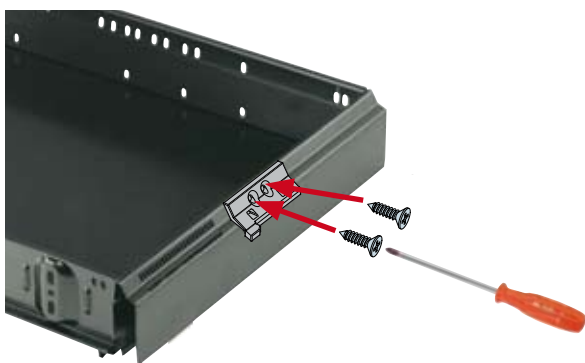
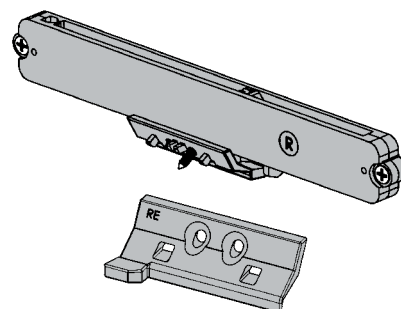
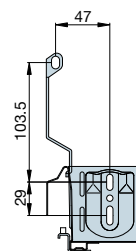

- Beide Mitnehmer mit den Senkschrauben sichern
- Secure both trigger plates with a screw
- Vissez les deux clips pour assurer la fixation

- U-Profil linke Seite
- Cabinet rail left side
- Profile de meuble côté à gauche

- U-Profil rechte Seite
- Cabinet rail right side
- Profile de meuble côté à droite

Mass- und Konstruktionsänderungen vorbehalten.  
The manufacturer reserves the right to change the specification without notice.  
Sous réserve de modifications de construction.

**MERZROLLER®**

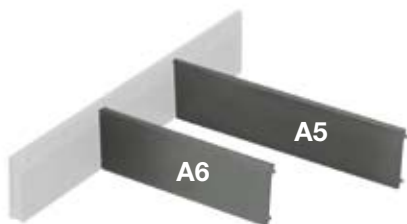

Unterteilungsplatten Subdivider elements Subdiviseurs	Dimension mm	Art.-Nr. / Ref.No. / N° de réf. schwarz RAL 9005 black noir	G	VE
	A5, 220	<b>0901802.61</b>	0.03	116
A6, 162	<b>0901803.61</b>	0.02	650	



Utensilien-Einsatzschale Pencil tray Bac pour ustensiles	Dimension mm	Art.-Nr. / Ref.No. / N° de réf. schwarz RAL 9005 black noir	G	VE
	326 x 326	<b>0901478.61</b>	0.41	25



Papier-Einsatzschale Paper tray Bac pour papier	Dimension mm	Art.-Nr. / Ref.No. / N° de réf. schwarz RAL 9005 black noir	G	VE
	326 x 326	<b>0901477.61</b>	0.35	25



- 3 Einsatzschalen pro Schublade
- 3 trays per drawer
- 3 bacs par tiroir

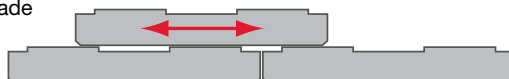

- ZMS 943.35 mit Utensilien- und Papier-Einsatzschale
- ZMS 943.35 with pencil tray and paper tray
- ZMS 943.35 avec porte ustensiles et compartiment à documents

## Accessories / Accessoires

## Plastic / Plastique

	Dimension mm	Art.-Nr. / Ref.No. / N° de réf. <b>schwarz RAL 9005</b> black noir	G	VE
<b>Hängerahmeneinsatz A4</b> Hanging file frame Cadre pour dossiers	327 x 327	<b>0901026.61</b>	0.736	16



	Dimension mm	Art.-Nr. / Ref.No. / N° de réf. <b>schwarz RAL 9005</b> black noir	G	VE
<b>Hängerahmeneinsatz 508</b> Hanging file frame Cadre pour dossiers	327 x 508	<b>0901027.61</b>	1.044	12



- ZMS 943.35 mit Hängerahmeneinsatz A4
- ZMS 943.35 with hanging file frame
- ZMS 943.35 avec cadre pour dossiers





Trennschied Metall BS Metal system divider Diviseur	Dimension mm	Art.-Nr. / Ref.No. / N° de réf. schwarz RAL 9005 black noir	G	VE
	330 x 65	0901728.61		1
480 x 65	0901729.61		1	

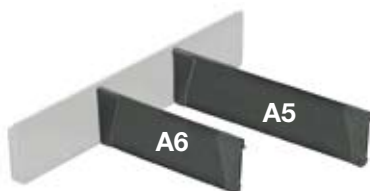

Metallunterteiler Metal subdivider elements Subdiviseurs en métal	Dimension mm	Art.-Nr. / Ref.No. / N° de réf. schwarz RAL 9005 black noir	G	VE
	A5, 226	0901731.61		1
A6, 167	0901732.61		1	
A7, 109	0901733.61		1	



- ZMS 943.35 mit Trennschied Metall BS und Unterteilungsplatten
- ZMS 943.35 with metal system divider and subdivider elements
- ZMS 943.35 avec diviseur et subdiviseurs

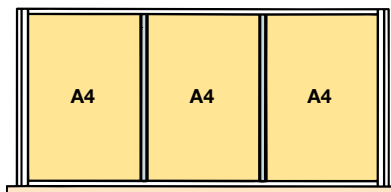

2 Trennschied Metall BS

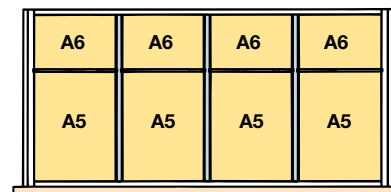
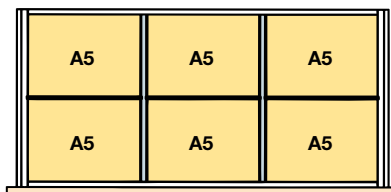
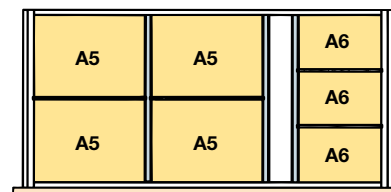
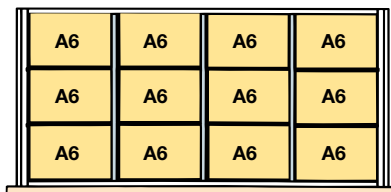
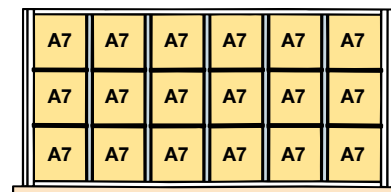
3 Trennschied Metall BS  
4 Unterteilungsplatten A62 Trennschied Metall BS  
3 Unterteilungsplatten A53 Trennschied Metall BS  
2 Unterteilungsplatten A5  
2 Unterteilungsplatten A63 Trennschied Metall BS  
8 Unterteilungsplatten A65 Trennschied Metall BS  
12 Metallunterteiler A7

	Dimension	Art.-Nr. / Ref.No. / N° de réf.	G	VE
	mm	schwarz RAL 9005 black noir		
<b>Karteibahn</b> Mounting file track Casier pour fiches	A4, 308x328	<b>0901031.61</b>	1.260	2
	A5, 215x328	<b>0901033.61</b>	0.968	2
	A6, 155x328	<b>0901121.61</b>	0.838	2
	A4, 308x478	<b>0901030.61</b>	1.836	2
	A5, 215x478	<b>0901032.61</b>	1.472	2
	A6, 155x478	<b>0901120.61</b>	1.272	2



	Dimension	Art.-Nr. / Ref.No. / N° de réf.	G	VE
	mm	schwarz RAL 9005 black noir		
<b>Schwenkblatt</b> Swivel insert Plaque coulissant	A4, 307x218	<b>0901036.61</b>	0.544	5
	A5, 214x156	<b>0901037.61</b>	0.262	5
	A6, 154x113	<b>0901122.61</b>	0.142	5
	A5 KT, 211x156	<b>0902590.61</b>	0.262	5



- ZMS 943.35 mit Karteibahn A5 kurz
- ZMS 943.35 with mounting file track
- ZMS 943.35 avec casier pour fiches



- ZMS 943.35 mit Karteibahn A6 kurz
- ZMS 943.35 with mounting file track
- ZMS 943.35 avec casier pour fiches



	Dimension	Art.-Nr. / Ref.No. / N° de réf.	G	VE
	mm	schwarz RAL 9005 black noir		
<b>Karteitrog</b> Mounting file track, mobil Bac à fiches, mobil	A4, 321x324	<b>0902663.61</b>		1
	A5, 225x324	<b>0902589.61</b>		1
	A6, 168x324	<b>0902664.61</b>		1
	A4, 321x478	<b>0903214.61</b>		1
	A5, 225x478	<b>0903354.61</b>		1
	A6, 168x478	<b>0903356.61</b>		1

